

## Zone5<sup>TM</sup> WALL MOUNTED OCCUPANCY SENSOR

### Installation Instructions

#### Hubbell Building Automation

9601 Dessau Road • Building One • Suite 100 • Austin, TX 78754

Toll Free: 888-698-3242 • Fax: 512-450-1215

www.hubbell-automation.com

#### DESCRIPTION

The Zone5<sup>TM</sup> ceiling-mounted occupancy sensor combines ultrasonic (US) and passive infrared (PIR) technologies to turn lighting on and off based on occupancy. The sensor features Hubbell's patented IntelliDAPT<sup>TM</sup> technology, which makes all the sensor's adjustments automatically. Throughout the product's lifespan, smart software analyzes the controlled area and makes digital adjustment to sensitivity and timer settings providing maintenance-free "Install and Forget" operation.

#### PRECAUTIONS

- **CAUTION: FOR USE WITH CLASS 2, LOW VOLTAGE SYSTEMS ONLY. DO NOT USE IN HIGH VOLTAGE APPLICATIONS.**
- Read and understand all instructions before beginning installation.
- NOTICE: For installation by a licensed electrician in accordance with National and/or local Electrical Codes.
- NOTICE: For indoor use only.
- **CAUTION: USE COPPER CONDUCTOR ONLY.**
- Confirm device ratings are suitable for application prior to installation. Use of device in applications beyond its specified ratings or in applications other than its intended use may cause an unsafe condition and will void manufacturer's warranty.
- NOTICE: Do not install if any damage to product is noticed.

#### OCCUPANCY SENSOR COVERAGE AND PLACEMENT

- The sensor must have an unobstructed view of the room. Do not mount behind or near tall cabinets, shelves, hanging fixtures, etc.
- Keep the sensor away from air flow – at least 8 feet from HVAC vents.
- Place the sensor 8-10 ft. away from doorway – pointing towards doorway for optimal occupant detection.
- Closely follow the diagrams for major and minor motion coverage.
- Decrease total coverage area by 15% for "soft" rooms (for example, heavy draperies or heavy carpeting).

#### INSTALLATION OPTIONS

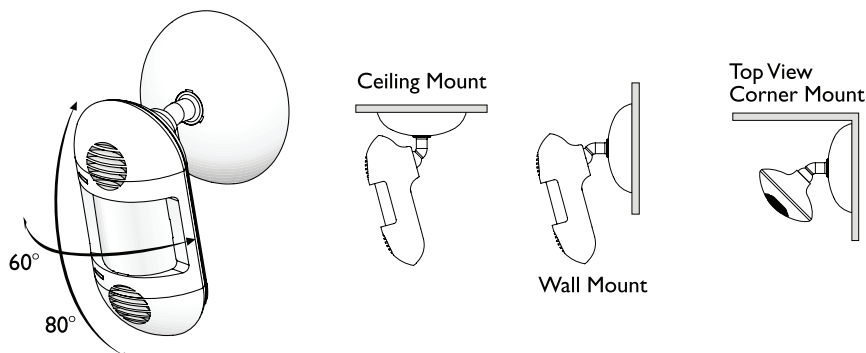

## INSTALLATION INSTRUCTIONS

### 1. Identify Parts (See Figure A)

- a. Cover
- b. Body
- c. Locking Screws
- d. Bracket Cover
- e. Wiring Harness
- f. Mounting Bracket
- g. Threaded Mounting Post
- h. Washer
- i. Nut

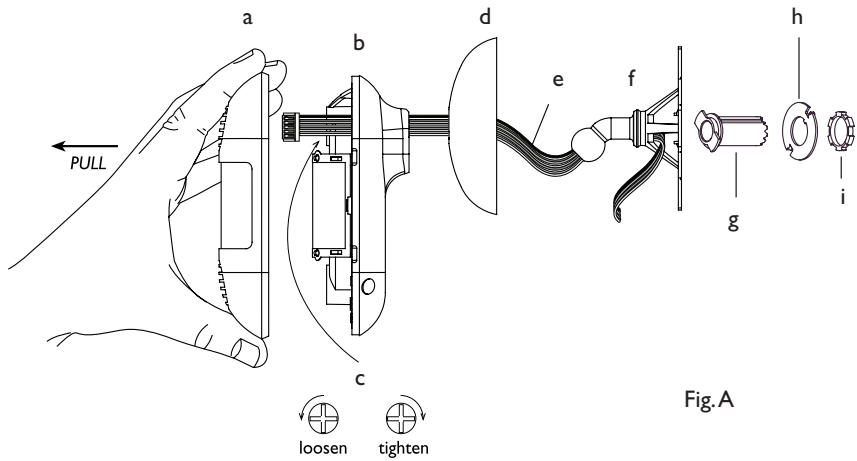

Fig. A

### 2. Insert Occupancy Sensor wiring with Quick-to-Install™ (QTI) connector through bracket legs. Secure bracket to wall. (See Figure B)

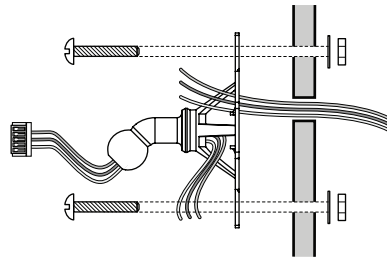

Fig. B

### 3. Plug the White CAT5 cable, available separately, into either of the two available White connector ports on the Zone5 Control Module. (See Figure C).



Fig. C

ZCM Low Voltage CAT5 Connector Ports (line voltage not visible in this image; no line voltage connection required for occupancy sensor)

4. Route the White cable from the Zone5 Control Module to the Occupancy Sensor. *Note: Low voltage wiring must be isolated from line voltage wiring. Consult national and Local Electrical Codes for conduit requirements.*
5. Plug the White cable QTI connector into the Occupancy Sensor's QTI connector. (See Figures D and E).

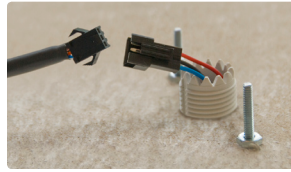

Fig. D

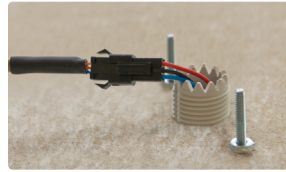

Fig. E

6. Snap bracket cover in place to conceal wiring and bracket. Feed wiring harness through the back of the sensor body and out exit slot. (See Figure F)

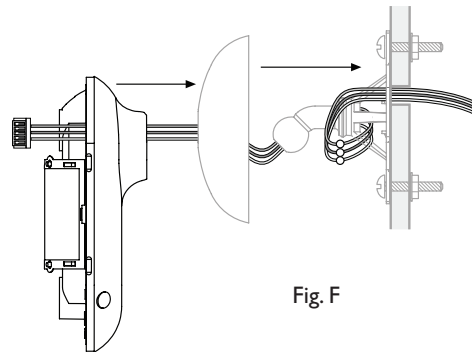

Fig. F

7. Snap sensor onto mounting post. Plug wiring harness into connector located on the left side opposite exit slot and place wiring under wire tabs. Align sensor and tighten position locking screw. Replace sensor cover. (See Figures G and H)

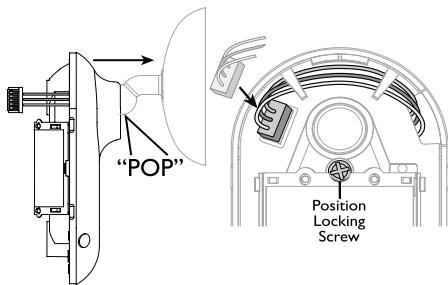

Fig. G

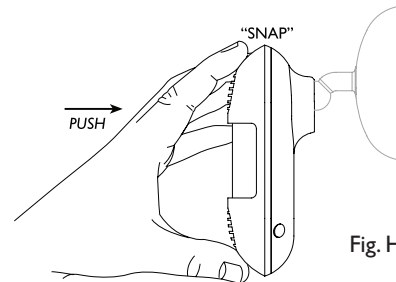

Fig. H

8. Perform system setup and/or programming activities as applicable in accordance with the instructions of the Zone5 Control Module.
9. Verify Occupancy Sensor functionality by checking System Status/ Occupancy Sensor on the Zone5 Control Module. Real-time occupied/ unoccupied states will be displayed if operating properly. If occupancy states do not change, check wiring.
10. If desired, to disconnect Occupancy Sensor from White ZCM cable, press down on the upper tab of the connection (located on the White cable side of the QTI connector.) Gently pull the two sides of the QTO connector apart. (See Figures I and J)

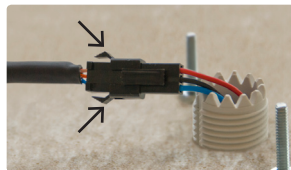

Fig. I

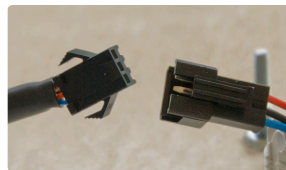
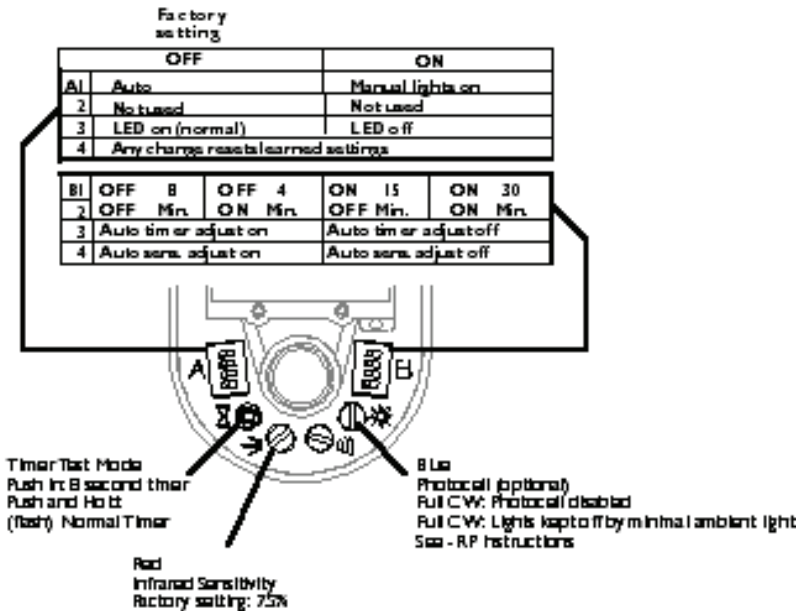

Fig. J

**SENSOR ADJUSTMENTS  
FACTORY SETTING**

**RECOMMENDATION:** Leave sensitivity settings as shipped.

Factory settings rarely need to be changed. In the unlikely event it is necessary to change a setting; the following diagram can be used. (See Figure K)



Recommendation: Leave sensitivity settings as shipped.

**TROUBLESHOOTING**

Problem	Possible Cause	Test	Result
Lights stay on	Air conditioning interference	Reduce both green and red knobs by 15%	Move sensor; temporarily reduce sensitivity
Lights stay on	Bad low voltage connection	Put sensor into test mode and check ZCM System Status/Occupancy Sensor to see if sensor changes from 'occupied' to 'unoccupied'.	Disconnect and reconnect wiring
Lights stay off	Bad low voltage connection	Put sensor into test mode and check ZCM System Status/Occupancy Sensor to see if sensor changes from 'unoccupied' to 'occupied'	Disconnect and reconnect wiring
Lights stay on too long	Timer setting too high	Check switch settings	Typical setting is 8 minutes
Hallway traffic turns lights on	Sensor can "see" into hallway	Put sensor in test mode and walk hallway	Move sensor



**Hubbell Building Automation, Inc.**  
 9601 Dessau Road | Building One | Austin, Texas 78754  
 {888} 698-3242 | {512} 450-1215 fax  
[hubbell-automation.com](http://hubbell-automation.com)  
 72-00469