



Ceiling and Wall Mount Occupancy Sensors

LightOWL™ Dual Technology Passive Infrared and Acoustic Sensor featuring IntelliDAPT®

KEY FEATURES

- IntelliDAPT self-adaptive technology—no manual adjustment required
- All-digital dual technology (passive infrared [PIR] and acoustic) sensor
- Non-volatile memory for sensor settings
- 1,600 square-foot coverage area
- Optional relay and photocell control
- Optional Quick-to-Install (QTI) connector
- UL and cUL listed
- California Title 24 compliant
- Five-year warranty



LODIA

OVERVIEW

The LODIA combines passive infrared (PIR) and acoustic (sound-activated) technologies to turn lighting on and off based on occupancy. This sensor features Hubbell Building Automation’s patented IntelliDAPT technology, which makes all the sensor adjustments automatically. Throughout the product’s lifespan, smart software analyzes the controlled area and makes digital adjustments to sensitivity and timer settings. Occupancy sensors with IntelliDAPT provide a maintenance-free install-and-forget operation.

FEATURES and BENEFITS

Features

Benefits

IntelliDAPT technology	<ul style="list-style-type: none"> • Sensor automatically determines the ideal setting for an area • Excellent false trip immunity (for improved accuracy) • No manual sensitivity or timer adjustments required • Provides a maintenance-free install-and-forget operation
All-Digital, dual technology (passive infrared [PIR] and acoustic) sensor	<ul style="list-style-type: none"> • Superior PIR long-range major-motion detection combined with acoustic detection technology
Non-volatile memory for sensor settings	<ul style="list-style-type: none"> • Learned and adjusted settings will not be lost during power outages
Optional relay and photocell control	<ul style="list-style-type: none"> • Easy integration with Building Automation Systems • Increases energy savings by preventing lights from turning on when there is sufficient natural light
Optional Quick-to-Install (QTI) connector	<ul style="list-style-type: none"> • Dramatically reduces installation costs by removing the time-consuming process of manually wiring a sensor to a power pack • Easy to install; fast and efficient; no cutting, stripping, or wire nuts required

APPLICATIONS

- Offices
- Small conference rooms
- Break rooms

SPECIFICATIONS

IntelliDAPT technology	<ul style="list-style-type: none"> • Auto reset from test setting • Self-adjusting timer • Self-adjusting passive infrared and acoustic thresholds • Automatic false-on/false-off corrections
LED lamp	<ul style="list-style-type: none"> • Red—infrared motion • Green—acoustic detection
Timer timeout	<ul style="list-style-type: none"> • Automatic mode: 8–30 minutes (self-adjusts based on occupancy) • Test mode: 8 seconds (for an easy check at installation)
Passive infrared (PIR)	<ul style="list-style-type: none"> • Dual-element pyrometer and 12-element cylindrical rugged lens
RP option	<ul style="list-style-type: none"> • Relay and photocell included • Relay: N/O + N/C contacts; SPDT; 500 mA rated @ 24 VDC; three-wire isolated relay • Photocell: adjustable natural-light override ranges from 0 to 100 foot-candles (0–1,000 lux)
Coverage	<ul style="list-style-type: none"> • 1,600 square feet
Power requirements	<ul style="list-style-type: none"> • 24 VDC, 33 mA (uses UVPP and MP-Series power pack—not included)
Output	<ul style="list-style-type: none"> • 24 VDC active high-logic control signal with short circuit protection and optional dry contact (see: RP Option)
Operating environment	<ul style="list-style-type: none"> • Indoor use only • Operating temperature: 32°–104°F (0°–40°C) • Relative humidity (non-condensing): 0%–95%
Construction	<ul style="list-style-type: none"> • Casing – Rugged, high-impact, injection-molded plastic KJB ABS Cycolac (UL-945VA) flame class rating, UV inhibitors • Color-coded leads are 6" long
Size and weight	<ul style="list-style-type: none"> • Size: 6.58" x 3.63" x 3.72" • Weight: 5.0 oz (142g)
Color	<ul style="list-style-type: none"> • Off-white
Mounting	<ul style="list-style-type: none"> • Mounting base provided • Recommended MAX mounting height: 12ft.
Certifications	<ul style="list-style-type: none"> • UL and cUL listed
Warranty	<ul style="list-style-type: none"> • Five years

ORDERING INFORMATION

Catalog Number	Description	Color	Coverage
LODIA	Passive Infrared and Acoustic Wall and Ceiling Sensor with IntelliDAPT	Off-white	1600 sq. ft.
LODIARP	Passive Infrared and Acoustic Wall and Ceiling Sensor with IntelliDAPT (Relay and Photocell)	Off-white	1600 sq. ft.

*Add QTI to end of catalog number for optional Quick-to-Install connector

RANGE DIAGRAM

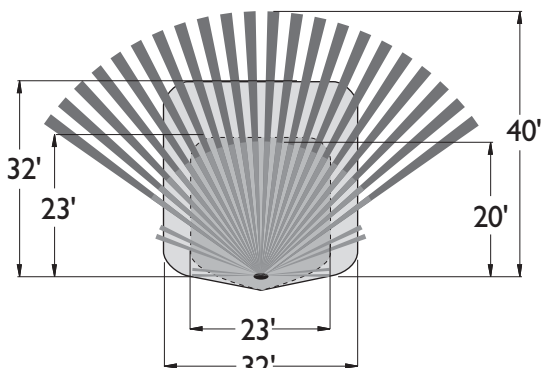

Building Automation, Inc.

Hubbell Building Automation, Inc.
 9601 Dessau Road | Building One | Austin, Texas 78754
 {512} 450-1100 | {512} 450-1215 fax
hubbell-automation.com